

STORAGE CALORIFIERS

Steam, Water, Electric or other primaries

- *Direct & Indirect Cylinders*
- *Thermal Storage Vessels*
- *Buffer Tanks*
- *Pressure Vessels
are JKKP (DOSH) Approved*



ate

ZOE INTERNATIONAL PTE LTD
1 International Business Park #B1-18, The Synergy
Singapore 609917
Tel: (65) 6897 5662 Fax: (65) 6897 5663
Email: zoeintl@singnet.com.sg

DIMENSIONS & WEIGHTS

STANDARD CONNECTIONS

- G Primary Flow or Steam
- H Primary Return or Condensate
- J Secondary Flow
- K Secondary Return
- L Cold Feed
- M Thermostat
- N Drain
- O Thermometer
- P Pressure Gauge
- Q Safety Valve

OPTIONAL CONNECTIONS

- R Bursting Disc
- S Anti Vacuum Valve
- T Manhole
- U Typical Leg for Steel Vessel
- V Leg for Copper Vessel
- W Cradles

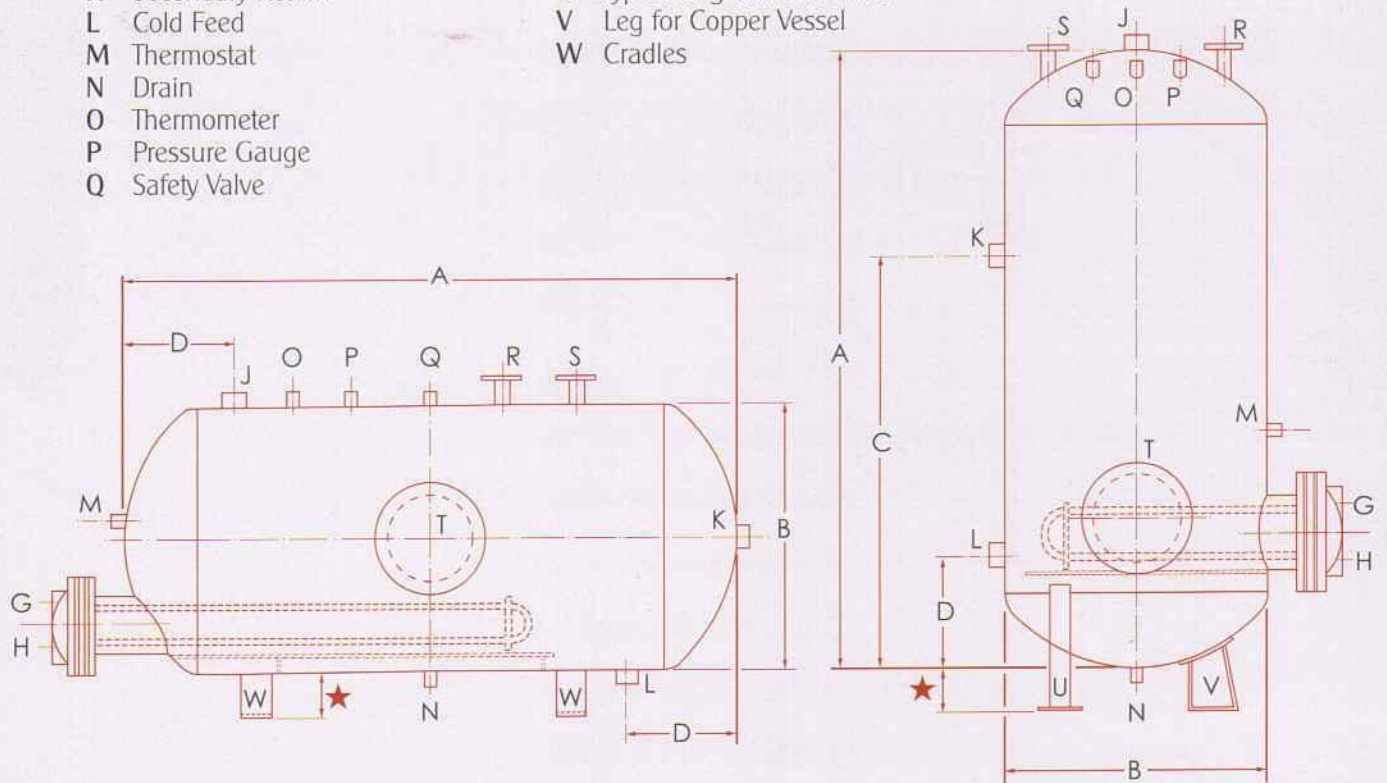

CAPACITY LITRES	DIMENSIONS mm/ins							
	A		B		C		D	
440	1800	71	600	24	1350	54	250	10
550	1700	67	675	27	1150	45	300	12
700	1750	69	750	30	1150	45	300	12
800	1950	77	750	30	1300	52	300	12
900	2000	79	800	32	1350	54	330	13
1000	1950	77	850	33	1300	52	330	13
1200	2100	83	900	36	1400	56	345	14
1350	2350	93	900	36	1550	62	345	14
1500	1950	77	1050	42	1300	52	395	15
1800	2300	91	1050	42	1550	62	395	15
2000	2500	98	1050	42	1650	66	395	15
2300	2400	94	1150	45	1600	64	410	16
2500	2450	96	1200	48	1650	66	430	17
3000	2900	114	1200	48	1950	77	430	17
3500	2700	106	1350	54	1800	71	475	19
4000	3050	120	1350	54	2050	81	475	19
4500	3400	134	1350	54	2250	89	475	19
5000	3200	126	1450	57	2400	94	500	20
6000	3800	150	1450	57	2850	112	500	20
7000	3300	130	1680	66	2475	97	475	19
8000	3700	146	1680	66	2850	112	475	19
9000	4200	165	1680	66	3150	124	475	19
10000	4600	181	1680	66	3600	142	475	19
12500	5000	197	1830	72	3750	148	550	22
15000	6000	236	1830	72	4500	177	550	22